



RioOutdoors.com

## #O-SPD Installation Instructions

**WARNING:** If the information in these instructions is not followed exactly, weakening or failure of the erected structure may result causing property damage, personal injury, or loss of life.

All brackets designed and sold by RioOutdoors.com are to be used for building pergolas only and are not to be used for other structure construction purposes.

### #O-SPD OCTAGON SPIDER BRACKET

Qty 1  
SKU # O-SPD  
Octagon Spider Bracket

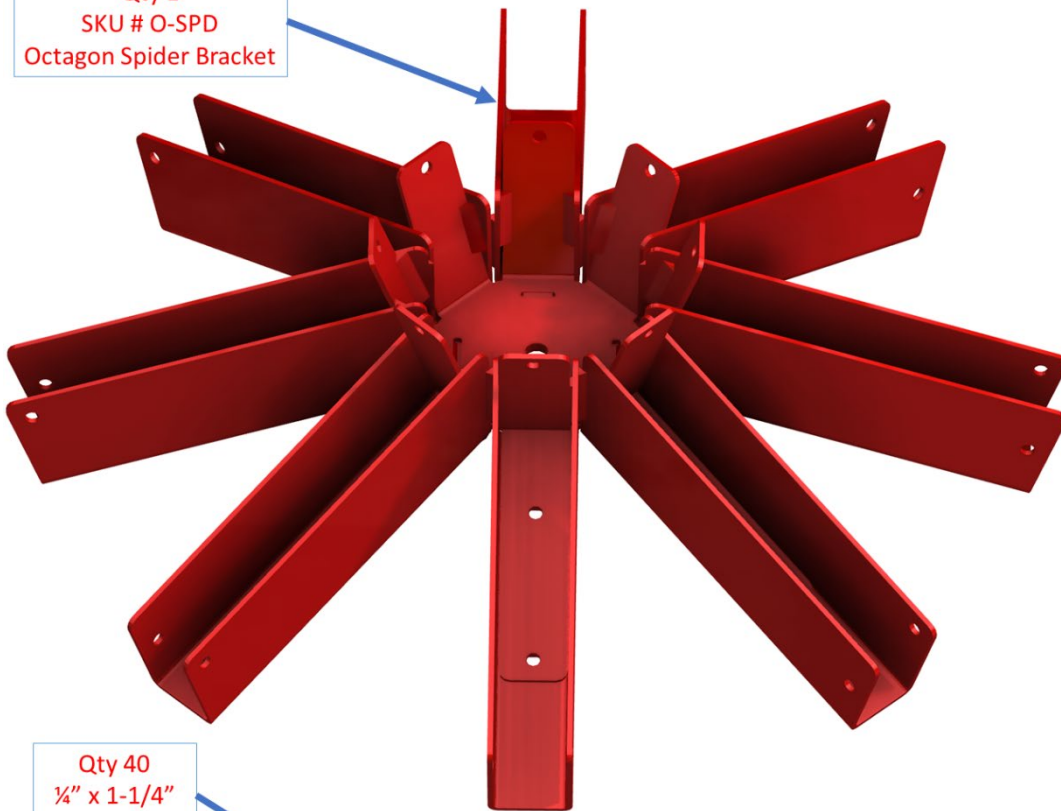

Qty 40  
1/4" x 1-1/4"  
LAG SCREWS



## TABLE OF CONTENTS

<b>1</b>	<b>#O-SPD SPECIFICATIONS</b>	<b>3</b>
<b>2</b>	<b>GENERAL INFORMATION</b>	<b>4</b>
2.1	SAFETY INFORMATION .....	4
2.2	TOOLS REQUIRED.....	4
2.3	CONTENTS OF BRACKET # O-SPD.....	5
<b>3</b>	<b>INSTALLATION INSTRUCTIONS</b>	<b>6</b>
3.1	CREATING THE STARTER RAFTERS ASSEMBLY .....	6
3.2	INSTALLING THE STARTER RAFTERS ASSEMBLY .....	12
3.3	INSTALLING ALL RAFTERS, ITEM A .....	14

**Proper pilot hole diameter and depth for various lag screws and wood types**

Lag Screw Type	Wood Type	Pilot hole drill diameter and depth
1/4" X 1-1/4" Lag Screw	Soft Wood	3/32" drill bit diam., 1-1/4" depth
	Hard Wood	3/16" drill bit diam., 1-1/4" depth
3/8" X 3" Lag Screw	Soft Wood	11/64" drill bit diam., 3" depth
	Hard Wood	1/4" drill bit diam., 3" depth

# 1 #O-SPD SPECIFICATIONS

Rafter Lumber Size: 2X Lumber only, 2x6 or 2x8

## #O-SPD SPECIFICATIONS

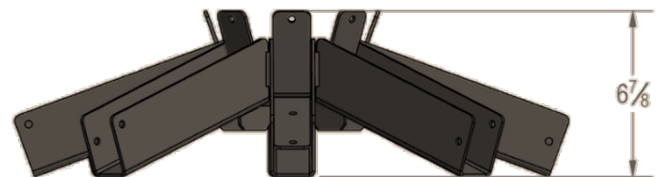
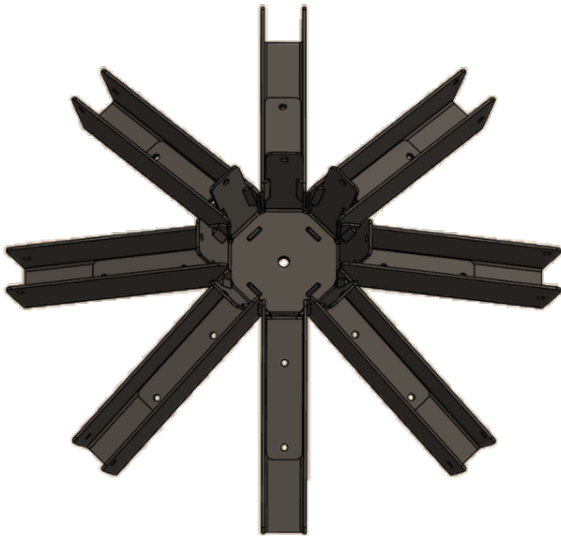
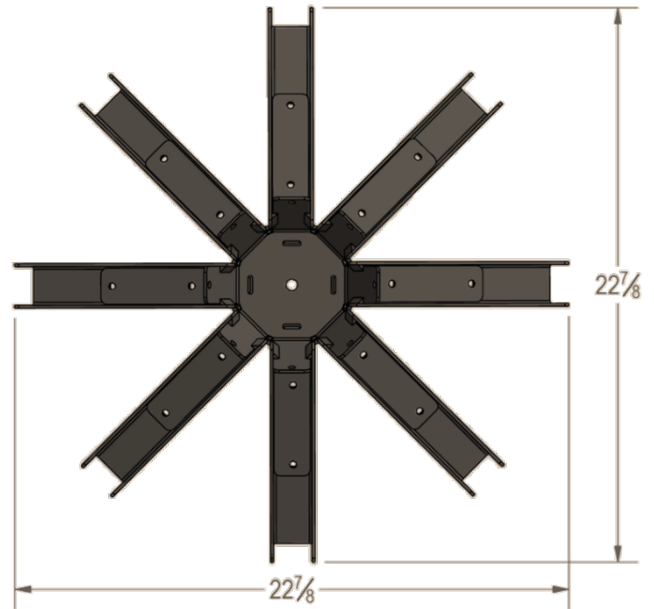

Weight: 22.5 lbs.

Metal Thickness: 1/8"

Paint Type: Powder Paint, Black

Rafter Pitch Angle: 20°

Rafter Lumber Size: 2x6 or 2x8

## 2 GENERAL INFORMATION

### 2.1 SAFETY INFORMATION

**CAUTION:** Adhere to all safety requirements. Wear safety glasses/goggles when working. Wear safety gloves when handling brackets, hardware, and lumber. Wear hearing protection when using a circular saw, miter saw, table saw, or hammer drill.

**INSTALLER:** Leave this manual with the consumer. **CONSUMER:** Retain this manual for future reference.

### 2.2 TOOLS REQUIRED

Listed below, are common tools required for pergola projects. These tools are not included in this kit. Your pergola project may not require all tools. Select and acquire the tools for your project from the "Required for" column in this table.



Description	Tool Purpose	Required for	Reference Image
Tape Measure	Measure and verify lengths.	All pergola types	
Framing Level	Verify Level/Plumb	All pergola types	
Hammer Drill	Drill holes in concrete pads or concrete footing for securing floor anchor brackets. Drill pilot holes for lag screws.	All pergola types	
Ratchet Socket Driver	Drive lag screws into Pergola lumber members.	All pergola types	
7/16" Hex Socket	Drive 1/4" X 1-1/4" Hex Hd. lag screws.	All pergola types	
3/32" Drill Bit	Drill pilot holes for 1/4" lag screws in soft wood.	All pergola types	
1/2" X 4" Masonry Drill Bit	Drill 1/2" X 2" deep holes in concrete pads or concrete footings.	Surface Mount styled pergola	
Circular Saw/Miter Saw	Cut headers to length; cut rafters to length.	All pergola types	
Crescent Wrench	Tighten down nut on concrete anchors.	Surface Mount Pergolas	Image not available.
Hammer	Various.	All pergola types.	

## 2.3 CONTENTS OF BRACKET # O-SPD

The contents of this Bracket are shown in the table, below.

Before you begin your project, take an inventory of all items that you received from us. If any items are missing, contact us directly via email at [info@RioOutdoors.com](mailto:info@RioOutdoors.com). Include your name and shipping address and your order number, if available. We will respond within 24 hours with a resolution to your problem.

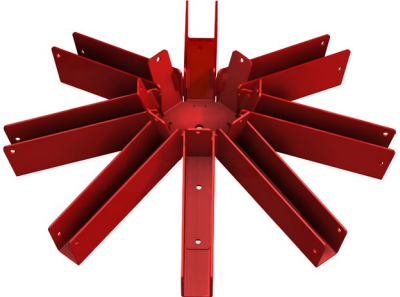
Please note that the bracket parts you receive may appear slightly different than those depicted in these instructions. We perform continuous improvements in our designs and update our current products accordingly. The parts you receive will contain our most-recent improvements and features.

Item SKU #, Description	Item Qty	Item Image
<p style="text-align: center;"><b>Octagon Roof Skirt Tie Bracket</b> <b>SKU# O-SPD</b></p>	<p style="text-align: center;"><b>1</b></p>	
<p style="text-align: center;"><b>1/4 x 1-1/4" Lag Screw</b></p>	<p style="text-align: center;"><b>40</b></p>	

### 3 INSTALLATION INSTRUCTIONS

#### 3.1 CREATING THE STARTER RAFTERS ASSEMBLY

Locate one (1) Octagon Spider Bracket, #O-SPD, and two (2) rafter members with the Octagon Cross Tie Brackets and Octagon Roof Skirt Tie Bracket installed on them.

The Starter Rafters Assembly is the last on-ground assembly that must be created. Once this assembly is created and installed on top of the octagon base structure, the installation of the remaining rafters will be super-simplified.

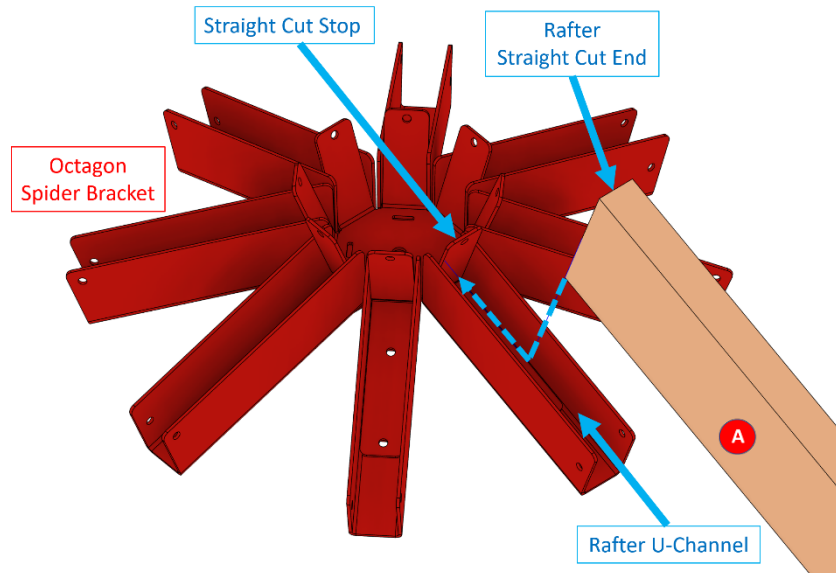

1. With the cross tie brackets at the bottom, slide the straight cut end of one rafter (A) inside one rafter U-Channel of the Octagon Spider Bracket. If the rafter is a tight fit in the U-channel, tap top surface of the rafter with a hammer to help it slide in.
2. Butt the straight cut end in the rafter member against the "Straight Cut Stop" face.

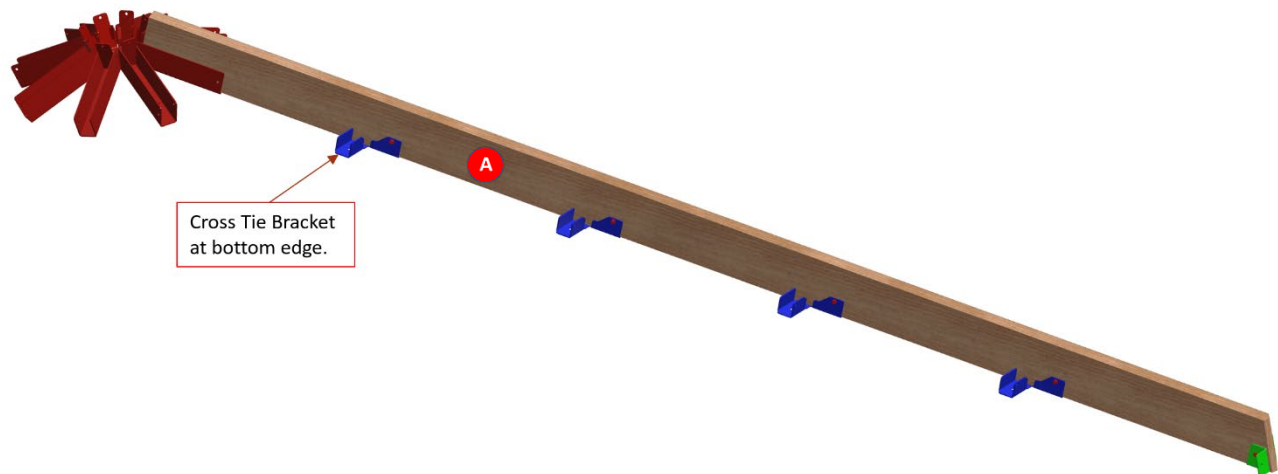

3. Flip the spider and rafter assembly upside down to expose two lag screw holes at the bottom of the rafter U-channel.
4. While pushing the rafter firmly against the "Straight Cut Stop," drill  $3/32"$  x  $1-1/4"$  pilot holes at the center of the two holes.

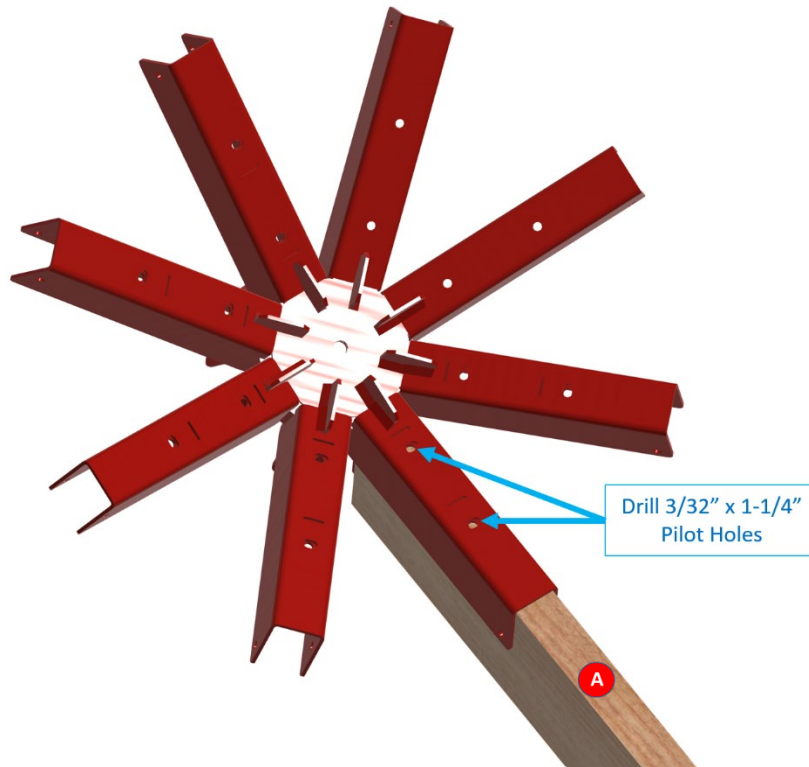

5. Drive one  $1/4"$  x  $1-1/4"$  lag screw through both pilot holes you drilled. Tighten the lag screws.

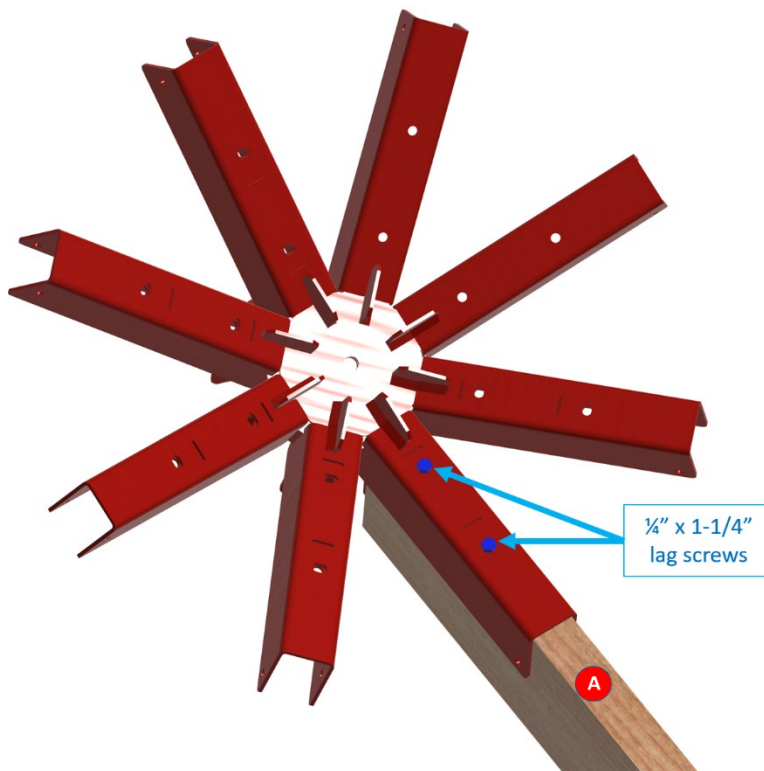

6. Identify 7/16" hole on the left side of the Rafter U-Channel. Drill a 3/32" x 1-1/4" pilot hole at the center of this hole.

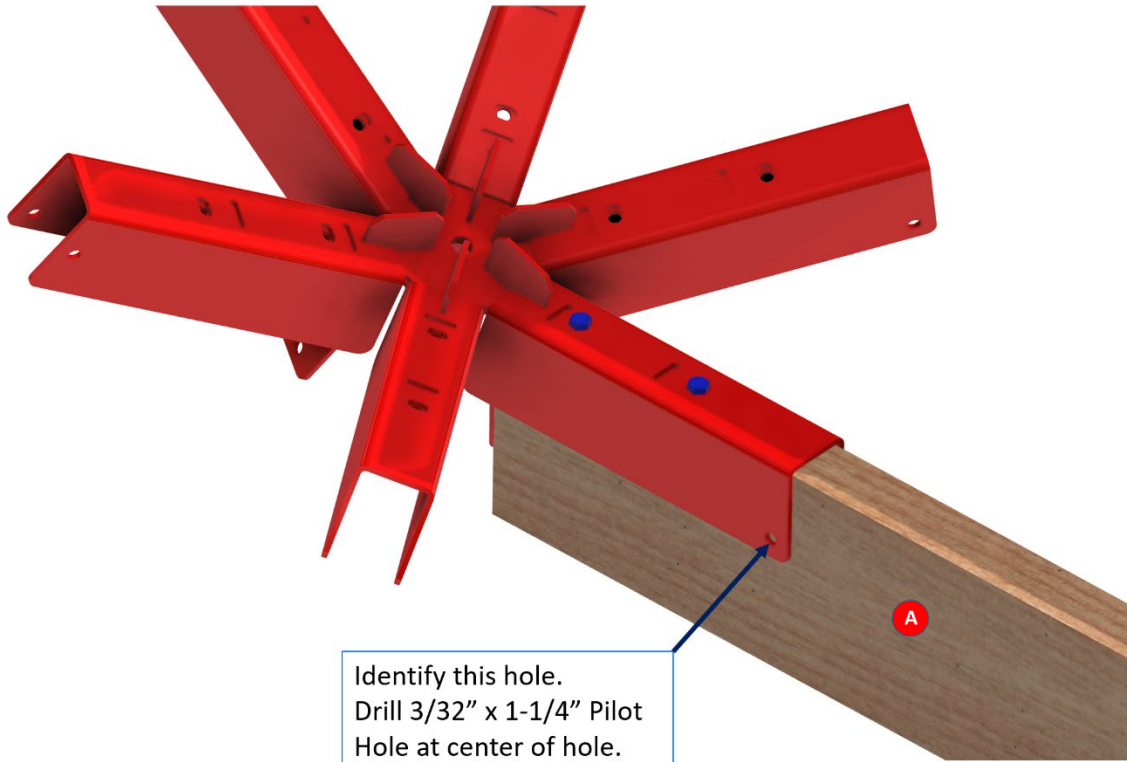

7. Drive one 1/4" x 1-1/4" Lag screw into pilot hole. Tighten the lag screw.

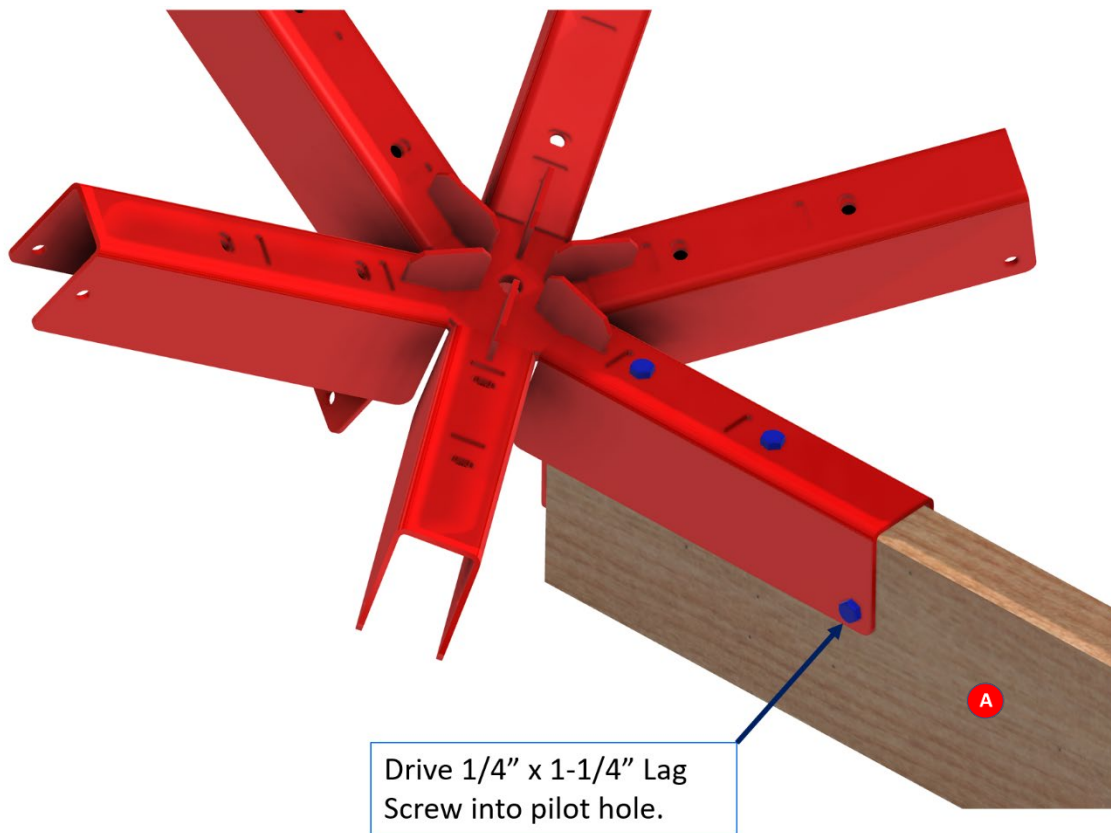



8. Identify the 7/16" hole located on right side of Rafter U-channel. Drill a 3/32" x 1-1/4" pilot hole at the center of the 7/16" hole.

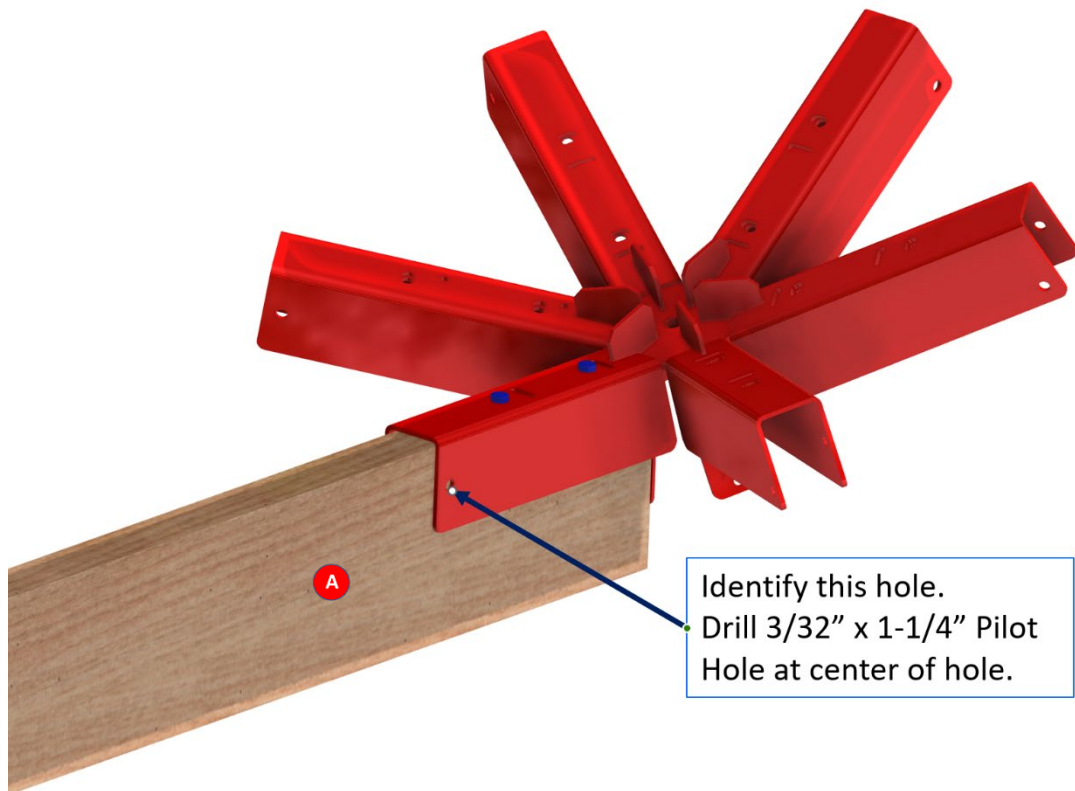

9. Drive a 1/4" x 1-1/4" Lag Screw into the pilot hole. Tighten Lag Screw.

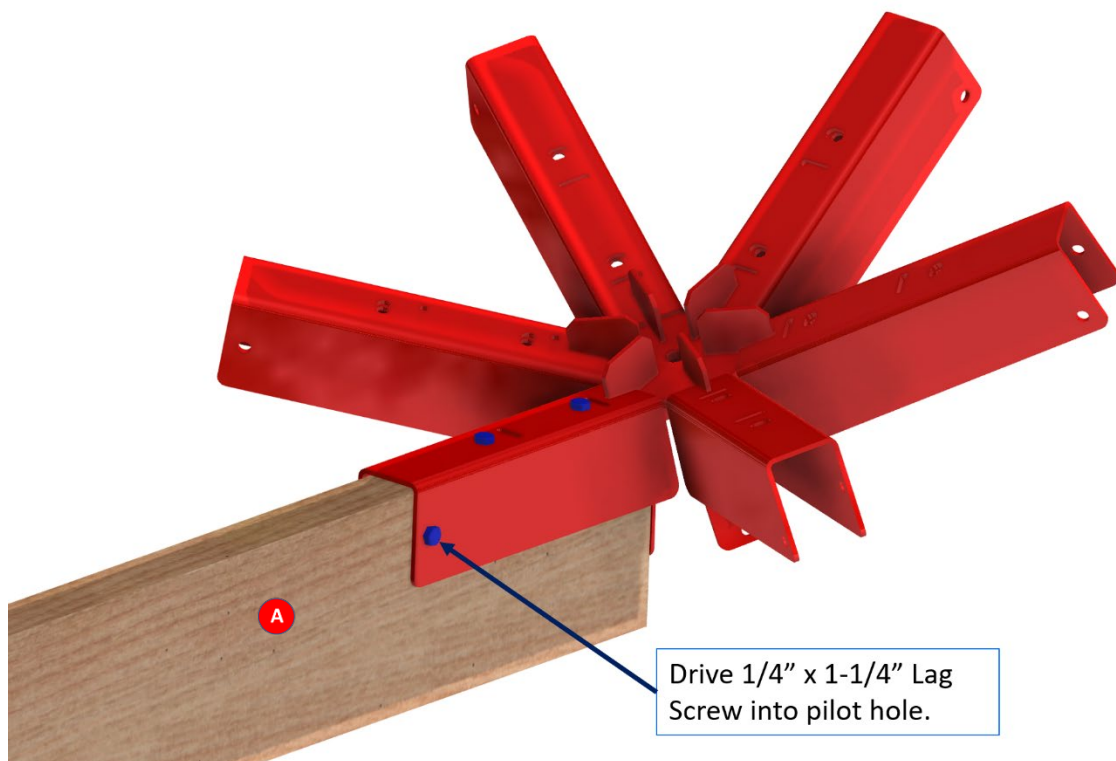

10. Flip the assembly over again. Drill a  $3/32$ " x  $1-1/4$ " pilot hole through the hole in the "Straight Cut Stop" face and into the straight cut edge of the rafter member

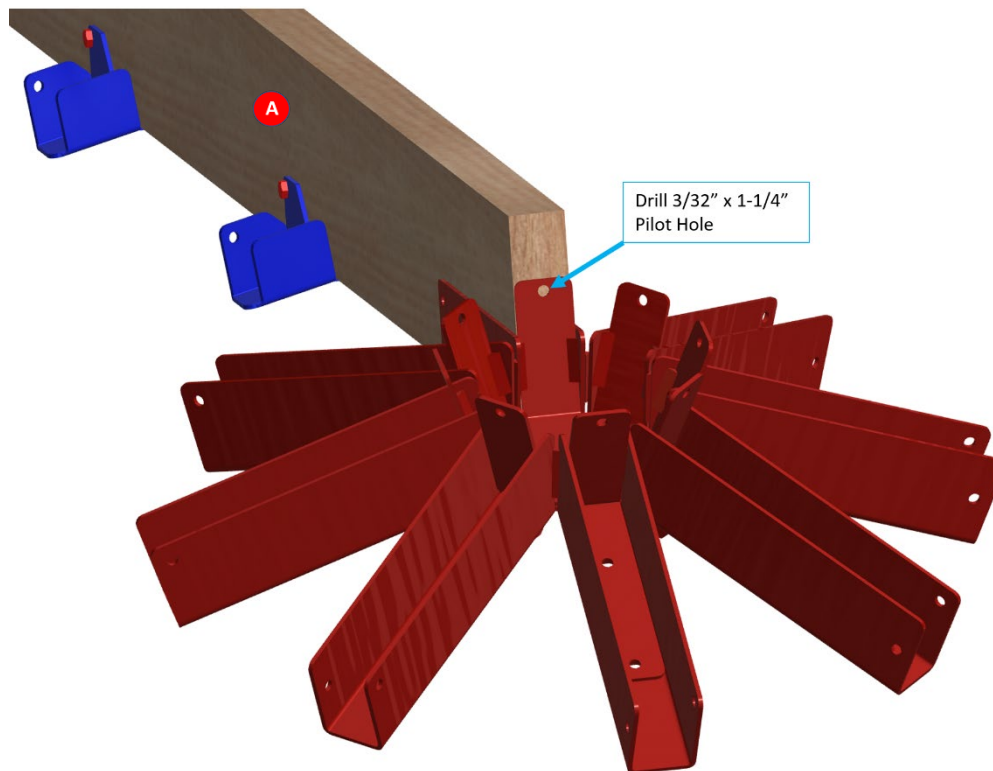

11. Drive one  $1/4$ " x  $1-1/4$ " lag screw into the pilot hole you drilled. Tighten the lag screw.

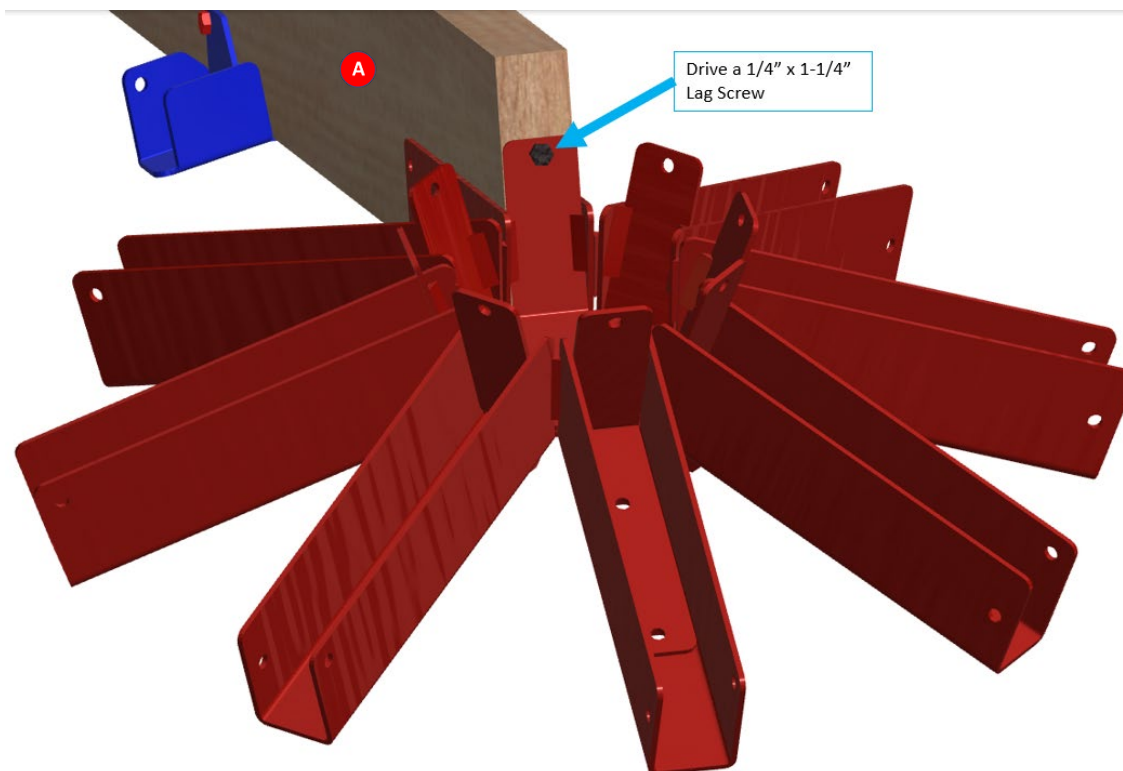

12. Identify the rafter U-channel on the opposite side of the rafter member you have installed on the Octagon Spider Bracket.

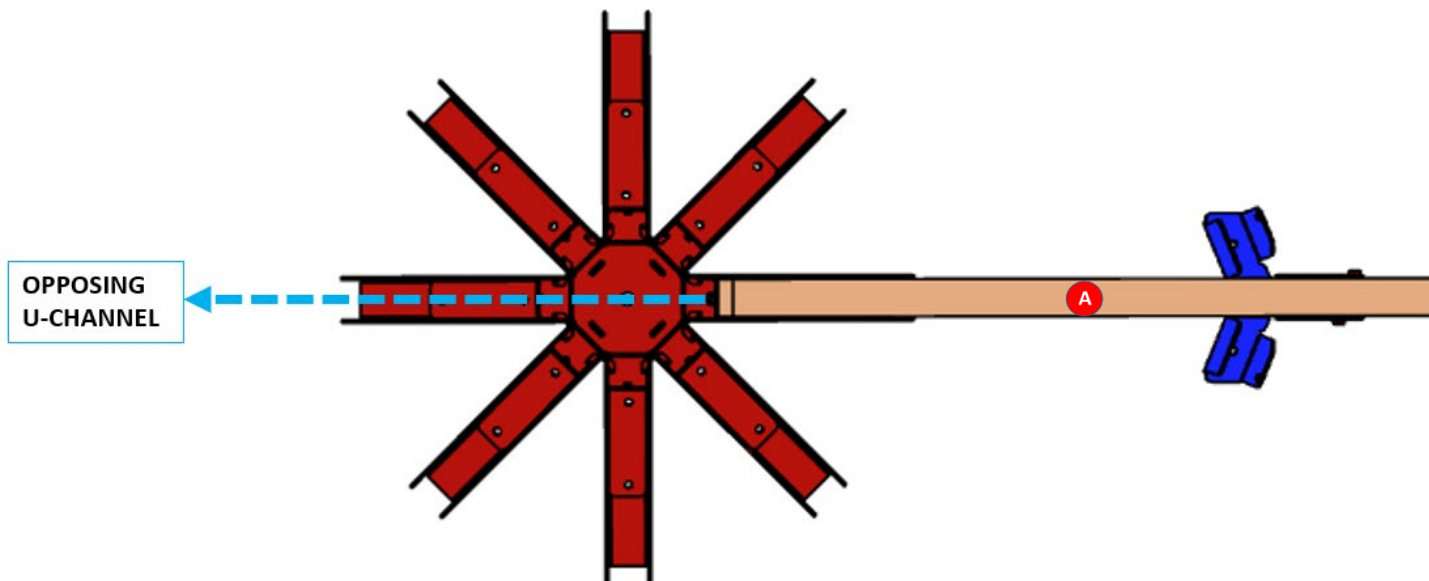

13. Repeat steps 1-11 to add a second rafter member with cross ties and roof skirt bracket to the opposing U-channel.

The Starter Rafters Assembly should appear as shown, below.

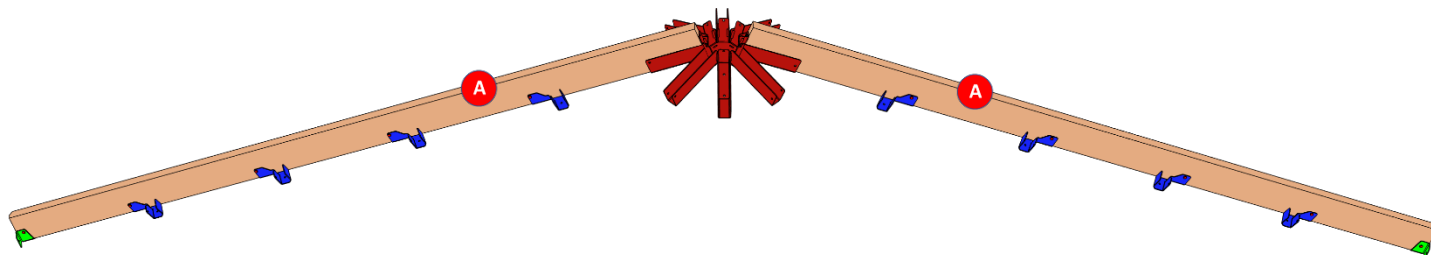

### 3.2 INSTALLING THE STARTER RAFTERS ASSEMBLY

Two people are needed to lift the Starter Rafters Assembly and place it inside two opposing post top rafter tie brackets. It does not matter which opposing corners you start at.

1. The Starter Rafters Assembly will be very stiff and solid. Lift the Starter Rafters Assembly and place the rafters inside the open U-channels in the post top rafter ties.

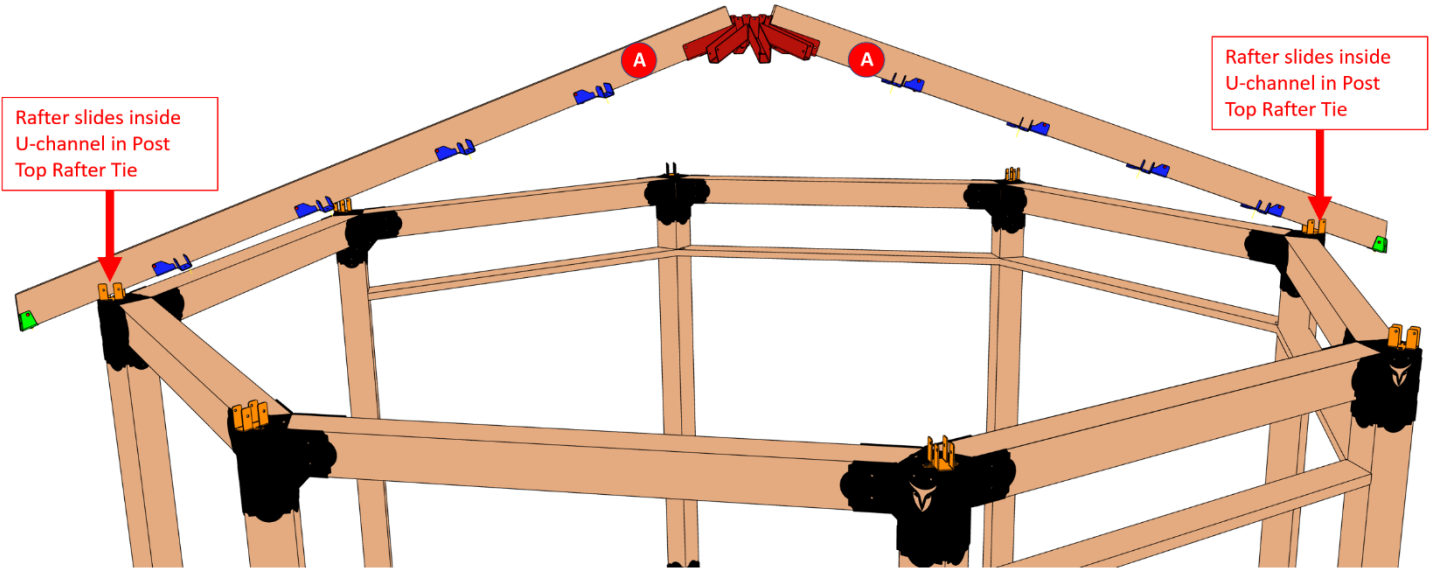

2. Measure the overhang on both sides. Center the Starter Rafters Assembly between the two corners by sliding it until the overhangs on both sides are equal.

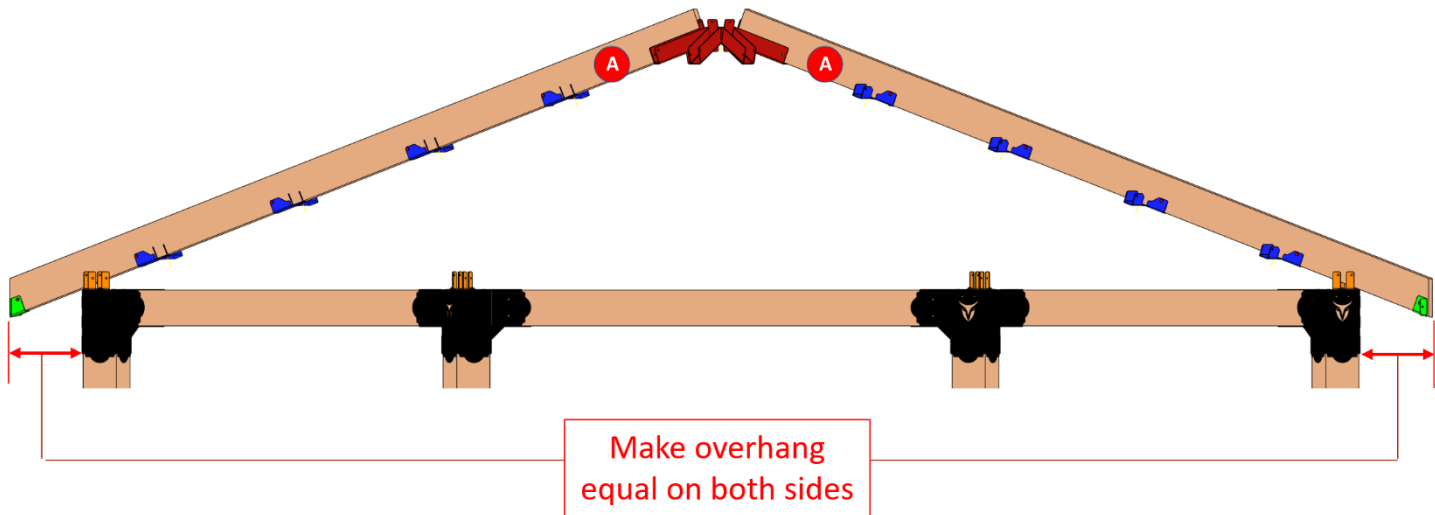

3. Drill  $\frac{3}{32}$ " x 1-1/4" pilot holes at the center of four holes each in both post top rafter tie brackets.

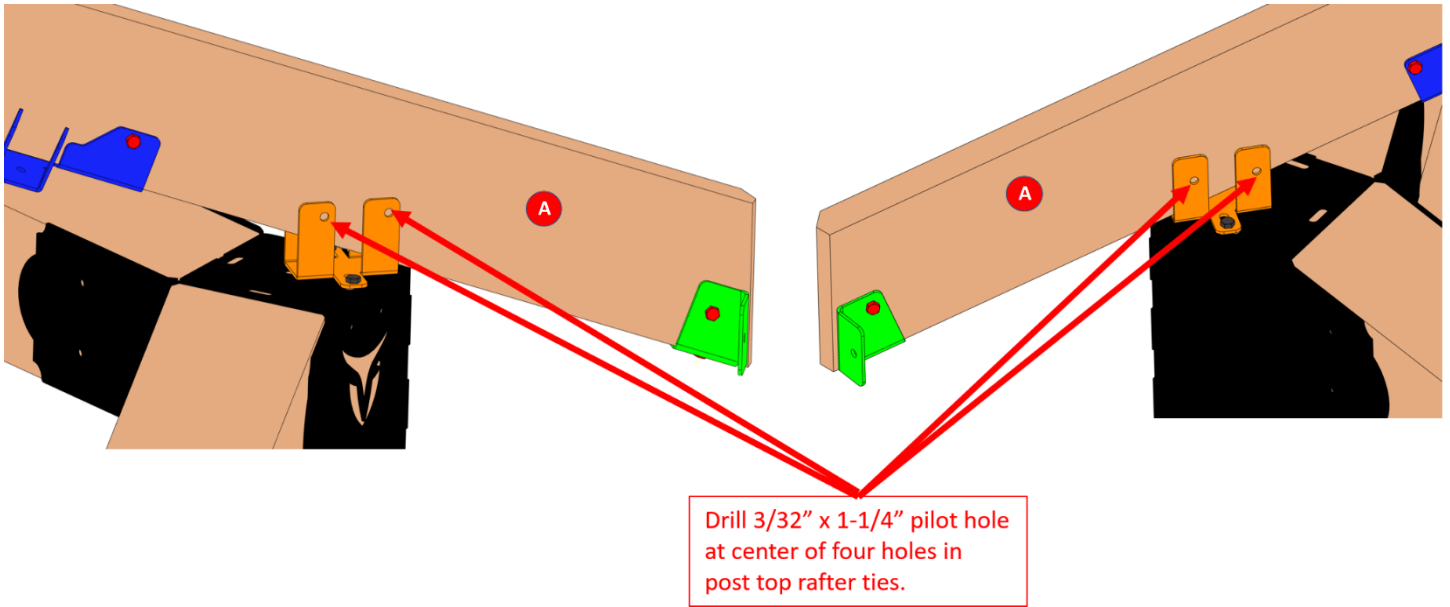

4. Drive  $\frac{1}{4}$ " x 1-1/4" lag screws into all pilot holes you drilled. Tighten the lag screws. Post Top Rafter Tie has holes on both sides of the rafter. Drive screws through holes on both sides of the rafter.

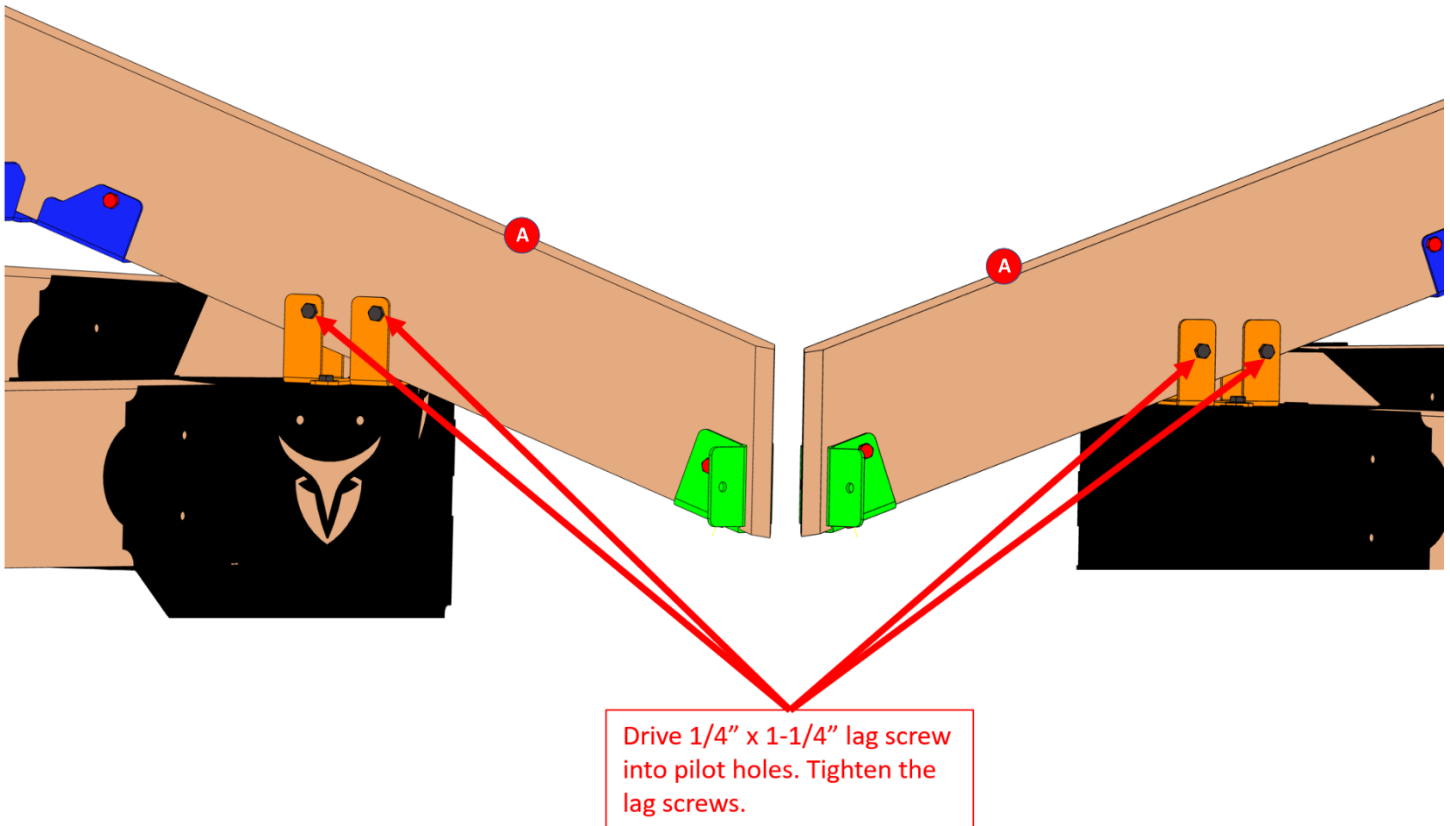

### 3.3 INSTALLING ALL RAFTERS, ITEM A

Obtain a step ladder. The step ladder will be needed to reach the roof peak octagon spider bracket to secure the remaining rafters.

1. First, add two rafters perpendicular to the rafters already installed in the Starter Rafters Assembly along the **1** arrow line.
2. Follow rafter installation steps provided in 3.1 to add the rafters along the **1** arrow line. Slide each rafter into its designated U-channel and its matching post top rafter tie at the corner posts. Secure the rafter to the Octagon Spider Bracket first. Then follow by securing the rafter to the post top rafter ties.

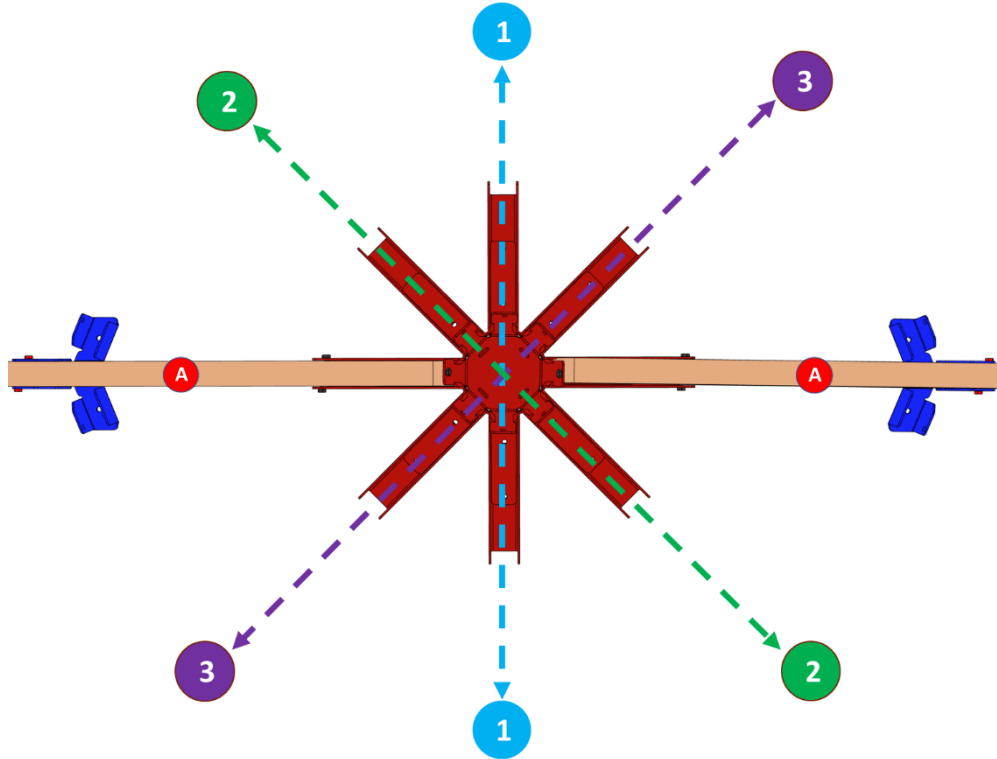

3. Next, add rafters along **2** and **3** arrow lines.
4. Drive screws to secure rafters to Octagon Spider U-Channels first, then drive screws to secure rafter to Post Top Rafter Ties. Tighten down all lag screws.